



Installation of Regulator Kit onto 1/4 in. molstic-S™ Mounting Platform

P/N 401880

Instruction Sheet

This kit is used to upgrade 1/4 in. single or dual molstic-S platforms that do not include the integrated pressure regulator. This upgraded configuration is ideal for the situation where the device under test (DUT) will be tested while plumbed downstream of the molbloc-S.



High pressure gases are potentially hazardous. Energy stored in these gases can be released unexpectedly and with extreme force. High pressure systems should be assembled and operated only by personnel who have been instructed in proper safety practices.

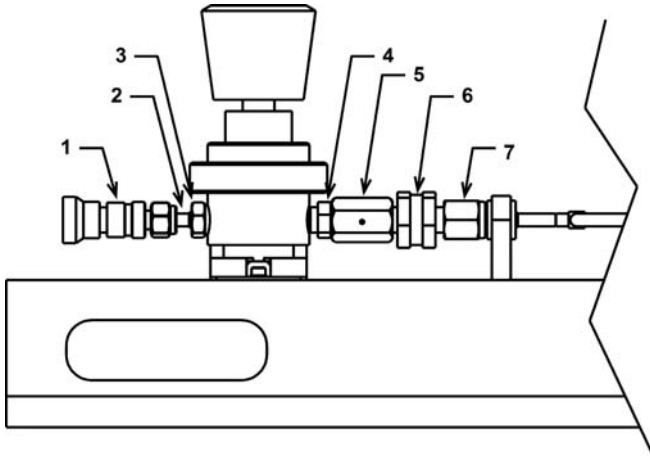

Figure 1. 1/4 in. molstic-S, with Regulation

PREPARING THE REGULATOR FOR INSTALLATION

- ❶ Place a new VCR® gasket (P/N 102183) into the inlet port of the regulator.
- ❷ Place the VCR male nut (3) over the tube adaptor (2) and thread it into the regulator inlet port and tighten finger-tight.



Over-tightening VCR connections will damage the sealing beads and possibly cause system leakage. Do not re-use metallic VCR gaskets.

- ❸ Hold the regulator stationary, and tighten the male nut 1/8 turn past finger-tight.
- ❹ Install the quick connect body (1) onto the tube fitting and tighten 1-1/4 rotations beyond finger-tight.
- ❺ Place a new VCR gasket into the outlet port of the regulator.

- ❻ Thread the VCR male union (4) into the regulator outlet port and tighten finger-tight.
- ❼ Hold the regulator stationary, and tighten the male union 1/8 turn past finger-tight.
- ❽ Attach the regulator mounting bracket to the base of the regulator using the two included #10-32 socket head cap screws, #10 flat washers, and the #10 lock washers. The long side of the bracket should be perpendicular to the direction of flow through the regulator.

INSTALLATION OF REGULATOR ONTO MOLSTIC-S

- ❶ Using a pair of properly sized wrenches remove the VCR x tube adaptor which is on the inlet end of the molstic-S. This will leave a VCR coupler (5) as the molstic interface. Retain the adaptor for future use. The VCR gaskets are for one-time use and should therefore be discarded.
- ❷ Using a pair of properly sized wrenches remove the VCR coupler and filter as an assembly (5 and 6) from the female VCR swivel nut (7). Discard the VCR gasket.
- ❸ Place a new VCR gasket securely against the sealing surface inside the female VCR coupler (5) of the molstic-S inlet fitting.
- ❹ Tighten the VCR coupler and filter subassembly to the regulator outlet fitting 1/8 turn past finger-tight.
- ❺ Place a new VCR gasket securely against the sealing surface inside the female VCR swivel nut (7).
- ❻ Place the regulator with its bracket on top of the molstic-S platform. Align the filter assembly's male VCR outlet fitting with the mating female VCR swivel nut and thread the nut onto the fitting.
- ❼ Hold the filter assembly stationary with a backup wrench. Tighten the female nut 1/8 turn past finger-tight.

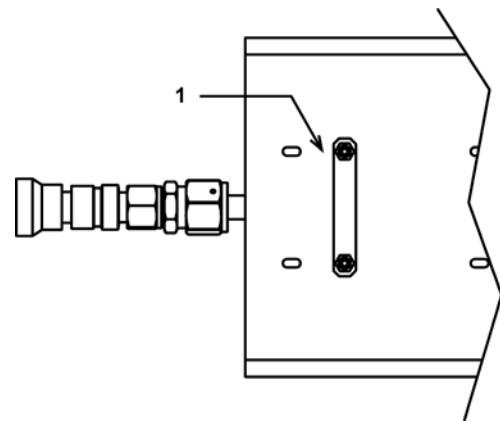

Figure 2. molstic-S Nut Plate

- ⑧ Place the flat side of the 60 mm nut plate (Fig 2, 1) under the molstic-S platform. Align it with the holes in the platform and the regulator bracket. Hold it in place.
- ⑨ Thread the two M4 socket head cap screws and M4 flat washers through the regulator bracket and tighten them securely into the nut plate.

SYSTEM PRESSURIZATION AND REGULATOR ADJUSTMENT



During system operation, be extremely careful not to apply pressure in excess of the maximum operating pressure of the molbox: 600 kPaa (87 psia) for molbox1-A700K; 250 kPaa (36 psia) for molbox1-A350K.

Once the test system with molbloc-S and molstic-S has been completely interconnected, the following procedure should be used for its safe pressurization and operation.

The outlet pressure of a pressure reducing regulator is controlled by adjusting the position of the control knob. Rotating the knob in the clockwise direction raises the outlet (control) pressure. Counterclockwise rotation, coupled with venting of the downstream side of the regulator plumbing, lowers the outlet pressure. molstic-S regulators are NOT self-venting so the outlet pressure will not decrease with counterclockwise rotation of the control knob unless the downstream gas is allowed to escape.

Make final adjustments of control pressure in the direction of increasing pressure in order to obtain the most accurate and stable set point.

System Pressurization

- ① **Set inlet pressure to minimum:** Turn the regulator's adjustment knob counterclockwise until the spring force has been relieved, and if so equipped close the shut-off directly downstream of the pressure control regulator.
- ② **Open molstic-S flow control/shut off valve(s):** Valves must be open to allow test gas to fill the test system.
- ③ **Plug-off/cap-off system:** Place a cap or plug (as applicable) on the outlet fitting of the test system.
- ④ **Isolate from vacuum system:** If the outlet plumbing of the molstic-S flows into a vacuum pump, disconnect or otherwise isolate from the vacuum system. When capping off ISO-KF style flanges use overpressure rings to insure a leak free connection at positive line pressure.
- ⑤ **Open DUTs flow control valve:** If the test system contains a DUT that has flow control capability, it must be slightly opened in order to allow pressure to pass through. All that is necessary is a small flow to allow the system to fully pressurize.
- ⑥ **Display system pressure:** Monitor the system pressure as measured by molbox by pressing the [P&T] function until the pressure is displayed. Refer to molbox Operation and Maintenance Manual for details.

- ⑦ **Turn on gas supply:** Apply the supply pressure to the pressure control regulator.
- ⑧ **Slowly raise system pressure to desired test pressure:** Rotating the regulator's control knob clockwise raises the outlet pressure. Rotate counterclockwise to lower the outlet pressure. Increase the system pressure to the desired DUT operating pressure. Make final adjustments of control pressure in the direction of increasing pressure in order to obtain the most accurate and stable set point.

Adjust the regulator to obtain the desired operating pressure. Provide additional margin only if the final pressure will be within the safe operating range of the molbox.

Regulator Adjustment

Once the regulator has been adjusted to the desired pressure its adjusting stem should be locked down to prevent further adjustments. This will help protect the molbox RPTs from over-pressurization.

- ① **Remove regulator knob cover:** Use a small flat screwdriver to remove the plastic cap on the top of the regulator adjustment knob.
- ② **Loosen jamb nut:** Using the properly sized socket wrench, loosen the jamb nut located on top of the adjustment knob.
- ③ **Adjust knob position:** Rotate the regulator adjustment knob clockwise until it gently bottoms out against the regulator body.
- ④ **Tighten jamb nut:** Hold the adjustment knob in position while using the socket wrench to tighten the jamb nut against the top of the adjustment knob.
- ⑤ **Retest system pressure:** Vent the system pressure. Repeat system pressurization procedure to verify the regulator pressure setting. Readjust if necessary.
- ⑥ **Replace regulator knob cover:** Place the regulator adjustment knob cover back on top of the knob and gently snap back in place.

The following parts are included in the shipment:

DESCRIPTION	QTY	PART NO.
Regulator, pressure reducing	1	103230
Regulator bracket	1	123657
Adaptor, 4VCR x 4T	1	102454
Male nut, 4VCR	1	102821
Gasket, 4VCR	4	102183
Quick connect body	1	102459
Quick connect stem	1	102458
Union, 4VCR male	1	103231
SHC screw, #10-32 x 3/8	2	103277-Z
Split lock washer, #10	2	103021-Z
Flat washer, #10	2	103278-Z
SHC screw, M4 x 12	2	101016-Z
Flat washer, M4	2	100918-Z
Nut plate, 60 mm	1	123621

molbloc, molbloc-S, molbox, molstic and molstic-s are trademarks, registered and otherwise, of DH Instruments, Inc.
VCR is a registered trademark of the Swagelok Company.