

PG7000™/RPM™ to PPC™/3990 Interconnections Kit

P/N 3069508

Installation Sheet

Interconnections Kit, P/N 3069508, Includes

DESCRIPTION	QTY	PART NO.
Adaptor, 1/8 in. Tube x 1/8 in. NPTM	2	3068564
Adaptor, 1/8 in. Tube x 1/4 in. NPTM	2	3068641
Adaptor, 1/4 in. Tube x 1/8 in. Tube stub	1	3135767
Plug, 1/8 in. Tube	1	3134224
Tee, 2T	1	3133091
Filter, 2T	1	3134584
Union, 2P	1	3135052
Reducer, 4P x 2P	1	3135076
Tubing, stainless steel, 1/8 in. OD x 100 cm LG	2	3232450
Quick Connect, AN4M	1	3068690
Quick Connect, 1/8 in. NPTF	1	3068708
Quick Connect and Stand Assembly	1	3124512

Parts on Test Port or in Accessories of PG7000

Collar	1	3068599
Gland	1	3068428
1/8 in. Tube x DH 200 M Adaptor	1	3069062

The 3069508 Interconnection Kit can be used for multiple applications. This installation sheet includes instructions for the following applications:

- ❶ PG7000/RPM4 as reference connected to PPC for pressure control and quick connect test stand for DUT with inline filter
- ❷ PG7000/RPM4 as reference connected to 3990 for pressure control and quick connect test stand for DUT without inline filter
- ❸ PG7000/RPM4 as reference connected to 3990 for pressure control and quick connect test stand for DUT with inline filter

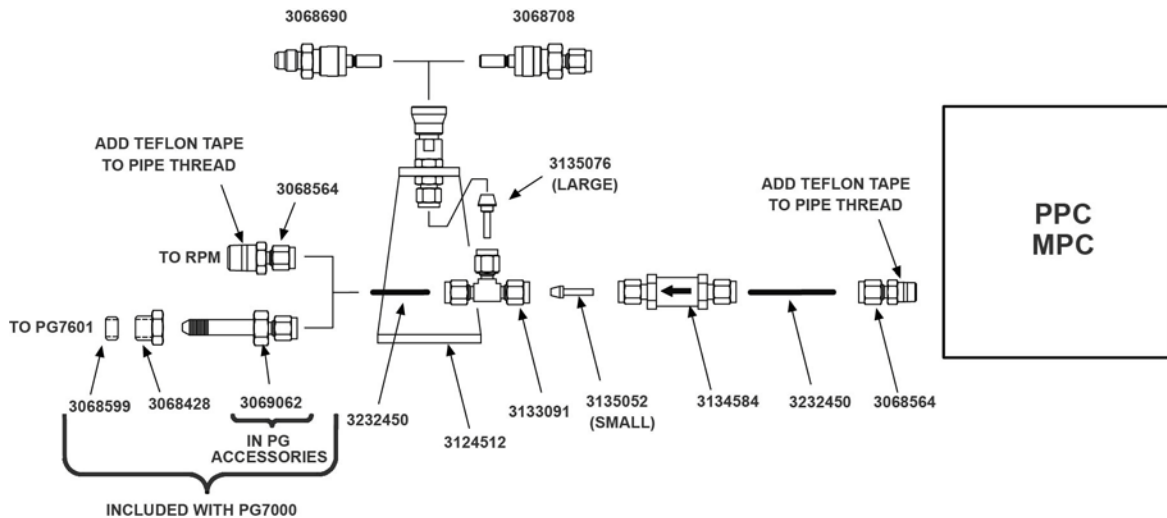

Figure 1: To Pneumatically Connect the PG7000 or RPM to the PPC or MPC

Note

If you are using an RPM (not a PG7000) go directly to Step ②b.

- ① Remove gland, collar and plastic plug from the PG7000 TEST port.
- ② Install gland and collar onto 1/8 in. tube x DH200 male adaptor supplied in PG7000 accessories.

Note

The collar has left-hand threads. Ensure the collar is securely attached. The plastic plug is not used.

- ③a PG7000 - Screw the adaptor (as assembled) into the PG7000 test port. Torque to 15 Nm (Newton meter).
- ③b RPM - Screw 1/8 in. tube x 1/8 in. NPT male adaptor into the RPM test port using teflon tape as seal.

- ④ Connect tee and filter assembly to quick connect stand assembly.
- ⑤ Screw 1/8 in. tube x 1/8 in. NPT male adaptor into PPC test port using Teflon tape as a seal.
- ⑥ Mount quick connect stand on bench (mounting holes provided).
- ⑦ To connect PG7000 or RPM test port to the quick connect stand cut 1/8" stainless steel tubing to desired length and Swage nut together.
- ⑧ To connect PPC to the quick connect stand cut 1/8 in. stainless steel tubing to desired length and Swage nut together.

Note

1/8 in. stainless steel tubing can be bent by hand to desired shape but use caution not to kink the tube.

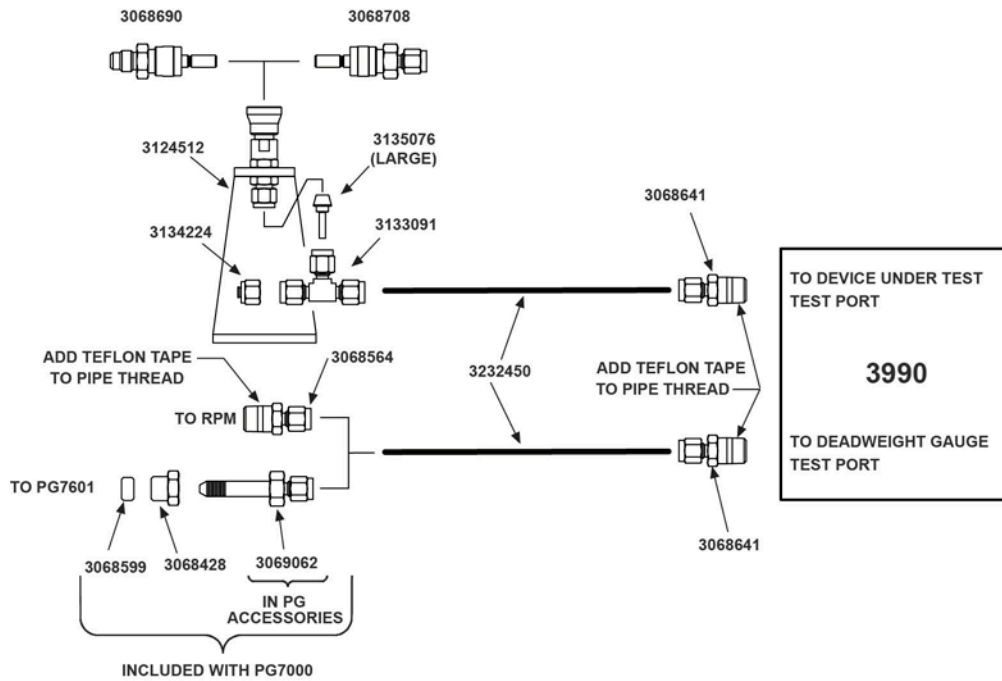

Figure 2: To Pneumatically Connect the PG7000 or RPM to the 3990 without a filter

Note

If you are using an RPM (not a PG7000) go directly to Step ③b.

- ① Remove gland, collar and plastic plug from the PG7000 TEST port.
- ② Install gland and collar onto 1/8 in. tube x DH200 male adaptor supplied in PG7000 accessories.

Note

The collar has left-hand threads. Ensure the collar is securely attached. The plastic plug is not used.

- ③a PG7000 - Screw the adaptor (as assembled) into the PG7000 test port. Torque to 15 Nm (Newton meter).
- ③b RPM - Screw 1/8 in. tube x 1/8 in. NPT male adaptor into the RPM test port using teflon tape as seal.

- ④ Connect tee to quick connect stand assembly using Reducer provided (3135076). Plug one end of the tee using 3134224 plug provided. Item 3135767 can be used in place of the tee if the stand is being placed at the end of the line.
- ⑤ Screw 1/8 in. tube x 1/4 in. NPT male adaptor into 3990 "TO DEVICE UNDER TEST, TEST PORT" using Teflon tape as a seal.
- ⑥ Screw 1/8 in. tube x 1/4 in. NPT male adaptor into 3990 "TO DEADWEIGHT GAUGE, TEST PORT" using Teflon tape as a seal.
- ⑦ To connect PG7000 or RPM test port to the 3990, cut 1/8 in. Stainless Steel tubing to desired length and Swage nut together.
- ⑧ To connect quick connect stand to the 3990, cut 1/8 in. Stainless Steel tubing to desired length and Swage nut together.
- ⑨ Mount quick connect stand on bench (mounting holes provided).

Note

1/8 in. stainless steel tubing can be bent by hand to desired shape but use caution not to kink the tube.

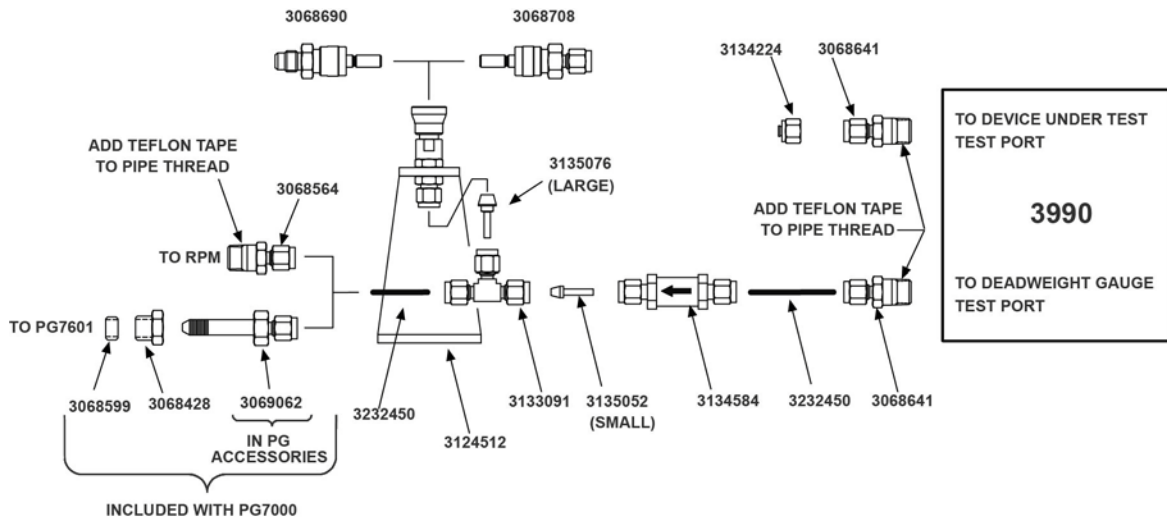

Figure 3: To Pneumatically Connect the PG7000 or RPM to the 3990 with a filter

Note

If you are using an RPM (not a PG7000) go directly to Step ②b.

- ① Remove gland, collar and plastic plug from the PG7000 TEST port.
- ② Install gland and collar onto 1/8 in. tube x DH200 male adaptor supplied in PG7000 accessories.

Note

The collar has left-hand threads.
Ensure the collar is securely attached.
The plastic plug is not used.

- ②a PG7000 - Screw the adaptor (as assembled) into the PG7000 test port. Torque to 15 Nm (Newton meter).
- ②b RPM - Screw 1/8 in. tube x 1/8 in. NPT male adaptor into the RPM test port using teflon tape as seal.
- ④ Connect tee and filter assembly to quick connect stand assembly.

- ⑤ Screw 1/8 in. tube x 1/4 in. NPT male adaptor into 3990 "TO DEVICE UNDER TEST, TEST PORT" using Teflon tape as a seal. Install the 1/8 in. tube plug into the adaptor.
- ⑥ Screw 1/8 in. tube x 1/4 in. NPT male adaptor into 3990 "TO DEADWEIGHT GAUGE, TEST PORT" using Teflon tape as a seal.
- ⑦ To connect PG7000 or RPM test port to the quick connect stand, cut 1/8 in. Stainless Steel tubing to desired length and Swage nut together.
- ⑧ To connect quick connect stand to the 3990, cut 1/8 in. Stainless Steel tubing to desired length and Swage nut together.
- ⑨ Mount quick connect stand on bench (mounting holes provided).

Note

1/8 in. stainless steel tubing can be bent by hand to desired shape but use caution not to kink the tube.

Fluke Calibration. Precision, performance, confidence.™

Electrical	RF	Temperature	Pressure	Flow	Software
------------	----	-------------	----------	------	----------

Fluke Calibration
PO Box 9090
Everett, WA 98206 U.S.A.

Fluke Europe B.V.
PO Box 1186, 5602 BD
Eindhoven, The Netherlands

For more information call:
In the U.S.A. (800) 443-5853 or
Fax (425) 446-5116
In Europe/M-East/Africa +31 (0) 40 2675 200 or
Fax +31 (0) 40 2675 222
In Canada (800)-36-FLUKE or
Fax (905) 890-6866

From other countries: +1 (425) 446-5500 or
Fax +1 (425) 446-5116
Web access: <http://www.flukecal.com>

©2011 Fluke Corporation.
Specifications subject to change without notice.
Printed in U.S.A. 8/2011 3152410B D-EN-N

Modification of this document is not permitted
without written permission from Fluke Corporation.