

Traceability and Quality Control in a Radiation Thermometry Laboratory

Frank Liebmann and Tom Kolat

Abstract: In radiation thermometry, a number of steps have been taken to improve calibration quality at temperatures below 1000 °C. These steps involve work done by national metrology institutes and standards bodies. The Fluke Infrared Calibration Laboratory in American Fork, Utah has benefitted from this progress and has established its own radiation thermometry program. The calibration range of this laboratory is -15 °C to 500 °C. This program involves calibrating radiometric transfer standards (with pyroelectric detectors) that, in turn, are used to calibrate flat-plate radiation sources, sometimes referred to as blackbodies. The transfer standards are calibrated by a sequence of blackbody cavity radiation sources that cover the entire temperature range of the laboratory. The radiometric transfer takes place between the cavity sources and the flat-plate sources. The intended use of the flat-plate sources is infrared thermometer calibration. Both the transfer standard calibrations and the flat-plate calibrations are accredited by the National Voluntary Accreditation Program (NVLAP). This paper discusses the traceability involved in this radiometric calibration program. It also discusses numerous quality control measures that have been taken to improve and assure measurement accuracy for both calibrations.

1. Introduction

In 2005, Fluke – Hart Scientific (now known as Fluke Calibration in American Fork and to be referred to as American Fork or AMF in this paper) began development of flat-plate IR calibrators that are calibrated using radiometric calibration. To support calibration of this product, a series of variable temperature liquid bath blackbodies were developed. These blackbodies support the calibration of a radiometric transfer standard that is used to calibrate the flat-plate calibrators. A number of steps were taken to ensure quality during the development of the radiometric temperature calibration program. Some of these steps are the result of research done internally; other steps are a result of the development of new standards.

2. Traceability

The read-out temperature of the flat-plate IR calibrators is based on a radiometric calibration, using the Heitronics model KT19II.82 (to be referred to as a KT19 in this paper) as a transfer standard. This instrument uses a pyroelectric detector [1]. An outline of the KT19 calibration scheme is discussed later in this paper.

The radiometric calibration was chosen over a contact calibration to account for factors such as emissivity [2] and heat exchange. The KT19 is calibrated using AMF's liquid bath blackbodies. A diagram of the blackbody is shown in Fig. 1. The temperature of the bath fluid during this calibration is monitored by a platinum resistance thermometer (PRT). The cavities have emissivity greater than 0.999 [2]. This number was verified by modeling with the STEEP3 software [3, 4, 5]. Newer methods exist to calculate blackbody emissivity [6], but were not available for this modeling. The inputs to this modeling were based on testing of blackbody uniformity [2]. One such result is shown in Fig. 2. The results in Fig. 2 show the temperature deviation on the cavity walls. At 150 °C the cavity had a 40 mK deviation in uniformity and a 60 mK

deviation at 250 °C. We utilized the results of this testing and modeling in our uncertainty budget for the KT19 calibration.

2.1 Traceability Scheme

The true temperature of the cavity baths is measured with a PRT located inside each bath. The PRT calibrations are performed in AMF's primary calibration laboratory and are traceable to the International System (SI) through the National Institute of Standards and Technology (NIST). The blackbodies' radiometric temperature is verified radiometrically by measurement with a Heitronics TRTII [7]. The TRTII is calibrated by NIST [8], and test results have shown normal equivalence [9]. A schematic of AMF's radiometric traceability chain is shown in Fig. 3., where the box labeled 'AMF IR Cavities' represents the liquid bath blackbodies discussed earlier. The 'AMF CL1' is the primary calibration laboratory in American Fork.

It would be more desirable to use the TRT transfer from NIST shown in Figure 3 as a direct radiometric traceability path. However, this method would result in larger uncertainties. An example of the difference in uncertainties between the two methods is summarized in Table 1.

2.2 Uncertainty Budgets

There are four different uncertainty budgets for AMF's radiometric calibrations. Two of these uncertainty budgets are for the two flat-plate calibrator models. The other two are for the KT19 calibration and the blackbody verification using the TRT.

The original uncertainty budget for the KT19 calibration was based on AMF's existing uncertainty analysis for contact thermometry [2]. Since the original uncertainty budget was developed, the Bureau International des Poids et Mesures (BIPM) has released a standard (*BIPM CCT-WG5*) for radiation thermometry uncertainty budgets

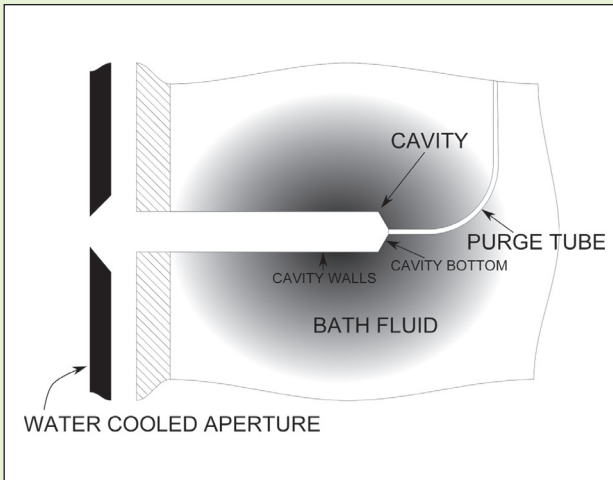

Figure 1. Liquid bath blackbodies.

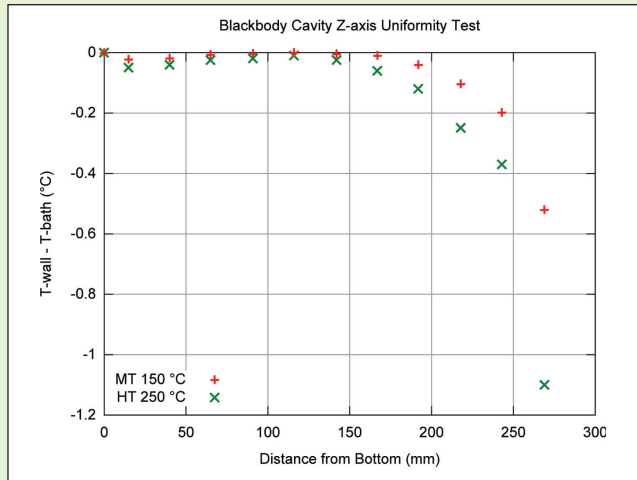

Figure 2. Blackbody uniformity test results.

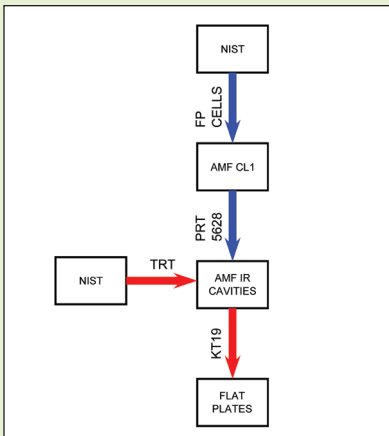

Figure 3. Radiometric traceability chain.

Calibration Point (°C)	Contact Scheme Uncertainty (k = 2) (K)	Radiometric Scheme Uncertainty (k = 2) (K)
-15	0.127	0.193
0	0.124	0.189
50	0.122	0.186
100	0.121	0.184
200	0.122	0.186
350	0.226	0.345
500	0.366	0.558

Table 1. Differences in uncertainties between contact and radiometric traceability.

[10], and AMF has reevaluated its uncertainty analysis. The WG5 standard places more detail on radiometric uncertainties and less on the contact uncertainty. Regardless, there was not a significant change in the uncertainties between the original evaluation and the new evaluation following the BIPM model.

3. Quality Control - Blackbody Sources

A diagram of the KT19 calibration is shown in Fig. 4. The steps taken to assure the

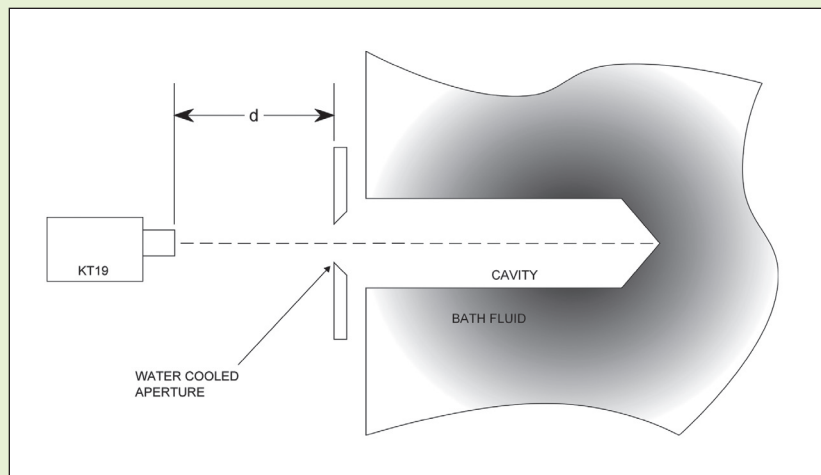

Figure 4. Transfer standard calibration geometry.

Authors

Frank Liebmann
Tom Kolat

Fluke Calibration
799 E. Utah Valley Dr.
American Fork, Utah
frank.liebmann@flukecal.com

quality of these calibrations include cross checks with a national metrology institute, determination of cavity uniformity, and use of a hot gas purge.

3.1 Cross-Checks and Verification
One check to verify the radiometric temperature of AMF’s cavities used a TRT calibrated at NIST [9]. The TRT calibrated

Blackbody	Nominal Temperature (°C)	Temperature Difference (K)	NIST Uncertainty (K) ($k = 2$)	AMF Uncertainty (K) ($k = 2$)	Normal Equivalence
LT	-15	0.074	0.34	0.128	0.20
LT	0	0.014	0.3	0.133	0.04
LT	50	-0.051	0.12	0.170	-0.25
LT	100	-0.125	0.11	0.218	-0.51
MT	100	-0.058	0.11	0.218	-0.24
MT	200	-0.155	0.12	0.335	-0.44
HT	200	-0.114	0.12	0.335	-0.32
HT	300	-0.144	0.13	0.226	-0.55
HT	350	-0.222	0.13	0.260	-0.76
HT	420	-0.253	0.14	0.317	-0.73
HT	500	-0.320	0.16	0.392	-0.76

Table 2. Normal equivalence results of comparison of American Fork blackbodies and NIST.

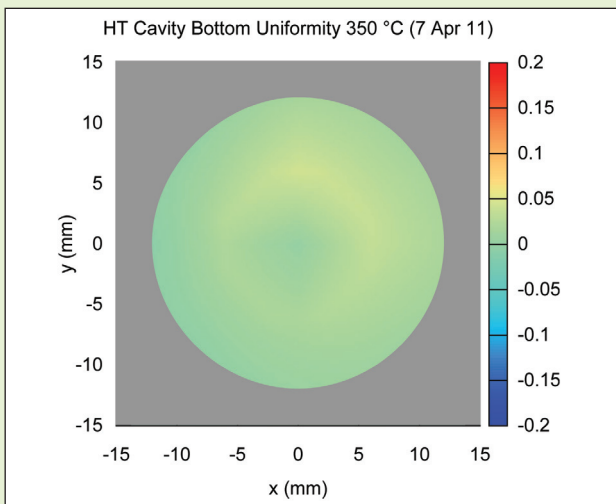

Figure 5. Cavity bottom uniformity.

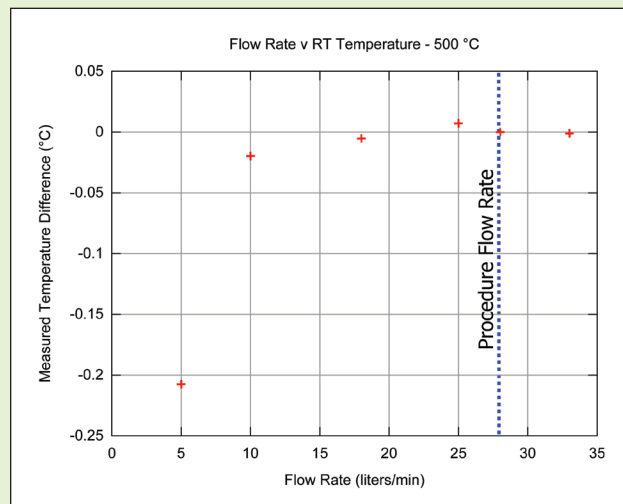

Figure 6. Blackbody purge flow rate test.

at NIST was used to measure the cavities at American Fork (Fig. 2). The temperature difference shown in Table 2 is the difference between AMF’s measurement and NIST’s measurement. Since this is a verification of the cavities’ temperature and not the traceability path of the cavities’ temperature to the SI, some of AMF’s uncertainties are less than NIST’s for the TRT measurement.

3.2 Cavity Uniformity

Along with the Z-axis uniformity testing shown in Fig. 2, testing has been done to determine cavity bottom uniformity. This testing is an important part of the KT19 uncertainty budget [10] and was done using a Heitronics TRT 2, by measuring points on the X-axis (vertical) and Y-axis (horizontal). The field-of-view of the TRT used for this test was 5.0 mm diameter (98 %), with a measuring distance of 362 mm. Fig. 5 is one set of data taken from this testing. The temperature map shown in this figure is created from this data. Temperature differences are referenced from the center of the cavity bottom.

3.3 Hot Gas Purge

To decrease the effects of temperature drop between the bath fluid and the cavity walls and to improve temperature uniformity, a hot gas purge is applied to the apex of the blackbody cone as shown in Fig. 1. The air goes through tubing and forms a helix inside the bath fluid. In this way, it reaches the bath temperature before it exits into the blackbody. Tests have been done to observe the effects of the purge on radiometric measurement. The results of one such test are shown in Fig. 6. The dashed line at 28 ℓ / min. represents the flow as indicated in AMF’s calibration procedures. The measured temperature difference is based on the difference from the measured temperature at a flow rate of 28 ℓ / min. The radiometric temperature of the cavity does not change significantly above half of the flow rate indicated in the procedure.

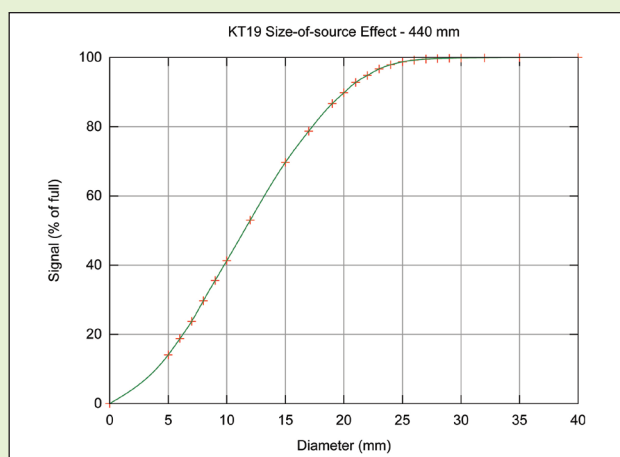

Figure 7. KT19 size-of-source testing results.

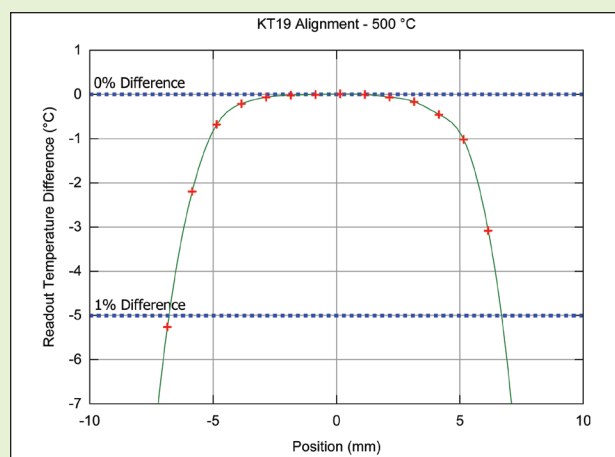

Figure 8. KT19 horizontal alignment.

4. Quality Control Measures – Transfer Standard Calibrations

A number of steps have been taken to assure trueness of the measurements in the transfer standard calibration. These steps include a self-consistency check using a chi-squared check [11] of data taken, an alignment procedure coupled with calculation of size-of-source effect uncertainty, an analysis of long term stability history, the use of cross-checks for verification of blackbody radiometric temperature, controlling transfer standard operating temperature, consideration of transfer standard warm-up time, and the use of a hot gas purge with the blackbody. A selected set of these steps is discussed below. A diagram of the transfer standard calibration geometry is shown in Fig. 4.

4.1 Size-of-Source Effect

The KT19 calibration uses a 35 mm diameter water cooled aperture. The aperture temperature is controlled near ambient and monitored as specified in AMF's calibration procedure. Size-of-source effect testing [12] on the radiometric transfer standard was done during the development phase of the project [2]. This testing followed a standard guideline [13] for testing size of source. Results of this are shown in Fig. 7 as size-of-source effect data. These data were used to determine aperture diameter and calculate aperture related uncertainties. In addition, tests were performed to determine the effects of varying aperture temperature and the test results were applied to the KT19 uncertainty budget.

4.2 Alignment

During the KT19 calibration process, the unit under test is mounted on a geared tripod head. The tripod head provides angular adjustment on two axes. The geared tripod head is mounted on an X-Y-Z carriage system that provides linear adjustment on three axes.

The angular alignment involves mounting a laser on the geared tripod head and angularly aligning the laser beam from the apex of the blackbody cone to the center of the aperture. After this, the KT19 is mounted on the tripod head. The distance is set between the aperture and the KT19 lens (Z-axis). Then the KT19 is aligned in the side-to-side direction (X-axis) and the up-and-down direction (Y-axis). For this procedure, a method from ASTM was considered [13]. However, it was found that signal received by the unit under test does not reach a definite peak during the calibration, but instead, forms a plateau

as shown in Fig. 8. Taking this into account, an alternative method for alignment was devised where the KT19 is moved along one axis until the displayed temperature drops off by 1 % of the displayed temperature or by 1 °C, whichever is greater. Then, the KT19 is moved along the same axis to the other side of the aperture center until another 1 % drop in temperature is observed. The KT19 is then moved to the center of these two points. This procedure is performed for both the X and Y-axes. Thus, the KT19 is centered in both directions.

A similar method has been suggested to determine size-of-source effect [14] by moving a radiation thermometer from side to side and noting its signal. This method uses a vertical slit as an aperture. AMF uses a circular aperture, so it may be possible to use a similar method with the data shown in Fig. 8 to determine size-of-source effect.

4.3 Long Term Stability History

The temporal stability of the reference standard must be considered when establishing traceability and evaluating uncertainty [15]. The instrument manufacturer's specifications are frequently used as an estimate for this component. In the case of this calibration, the stability of the Heitronics KT19 is provided in its specifications [1]. However, it was found that the KT19's stability was much better than its specifications, so this component of uncertainty was determined by measurements. A linear drift model was chosen by performing regression analysis on data obtained from 17 calibrations spanning 25 months.

The regression line confidence interval is a function of the number of data points and the fitting precision. The uncertainties of the individual data points were not considered because they are consistent from point to point and will be introduced into the evaluation elsewhere. Thus, the uncertainties of the projected line depend on the confidence interval and expand smoothly as a function of time. The equation used to determine the confidence interval [16] is shown in Eq. (1). A graph of one such set of data is shown in Fig. 9. A comparison of AMF's findings and the manufacturer's specification are shown in Table 3. In all cases, AMF's observed stability is much less than the manufacturer's specification. However, at the higher temperatures, AMF's observed stability is closer to the manufacturer's specification.

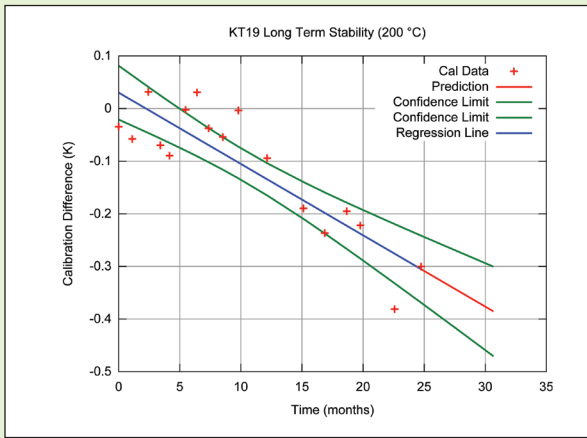

Figure 9. KT19 drift.

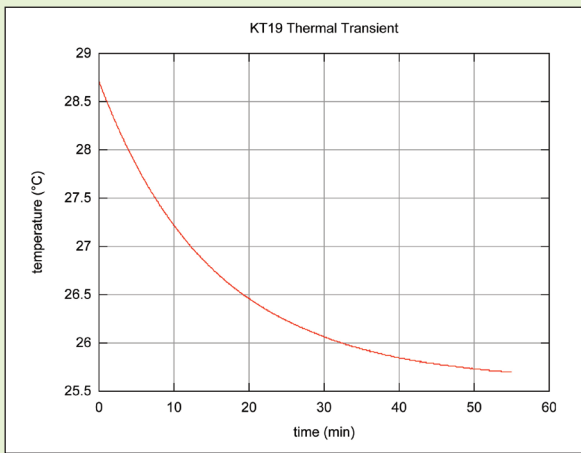

Figure 10. KT19 ambient temperature transient.

$$Var(y'_c) = s_{y'x}^2 \left[\frac{1}{n} + \frac{(X' - \bar{X})^2}{S_{xx}} \right] \quad (1)$$

where:

- $Var(y'_c)$ variance of estimate of a point on a fitted line
- $s_{y'x}$ sample variance of the temperature data curve fit
- n number of data points
- X' time under consideration
- \bar{X} sample mean of the time data
- S_{xx} variance of the time data

4.4 Transfer Standard Warm-up Time

AMF’s calibration procedure specifies that the KT19 should be warmed-up for 30 minutes prior to measuring the liquid bath blackbody temperatures. The reason for this warm-up time is based on the accuracy specification from the manufacturer of 15 minutes [1]. Further testing has been done to determine the transient time constant for warm-up. The result of one of these tests is shown in Fig. 10. In this test, the KT19 was enclosed in a temperature controlled water cooled jacket and its detector temperature was recorded over time. This data were fit to an exponential decay curve [17] with a time constant of approximately 15 minutes.

Temperature (°C)	Stability (mK / year)	Drift / year -Specification (mK / year)
-15	6.1	310.8
0	-6.2	327.8
50	-44.9	387.8
100	-101.3	447.8
200	-84.3	567.8
350	-163.8	747.8
500	-560.0	927.8

Table 3. KT19 stability summary.

5. Quality Control Measures – Flat-Plate Calibrations

AMF’s flat-plate calibrators are the models 4180 and 4181. A diagram of the flat-plate calibration scheme is shown in Fig. 11. A number of steps have been taken to reduce uncertainties in the flat-plate calibration. First, the reflected radiation is controlled at near room temperature. Second, for both the KT19 calibration and the flat-plate calibration, the radiometric temperature of the optical scatter is controlled by a water cooled aperture that is maintained at a constant temperature close to room temperature. Third, the lower temperature range of the flat-plate calibrators is -15 °C . There are two calibration points below ambient, -15 °C and 0 °C . Any radiometric calibration done between -15 °C and the dew point can cause dew or ice to form on the calibrator surface which in turn can cause variations in the radiation flux. Precautions, described below, have been taken to prevent this problem below the dew point.

5.1 Calibrations Below Ambient

To prevent problems with humidity below ambient, the 4180 calibration is done inside a purged chamber [2] that encloses everything between the KT19 and the flat-plate surface. This area is purged with a dry gas at a positive pressure. Humidity is monitored to ensure that the frost point inside the chamber is well below the calibration point. To ensure that no heat stacking or other thermal phenomena takes place on the IR calibrator surface, tests have been run to ensure that the thermal gradient and radiometric temperature on the surface is the same with and without the chamber at calibration temperatures above ambient. The results of these tests are shown in Fig. 12.

5.2 Calibration Quality Control Steps

Many of the quality control steps taken involve the calibration station. The calibration follows the same calibration geometry as the transfer standard calibration [2]. On the calibration station, the KT19 is mounted with the lens-cap removed. To ensure that foreign particles do not become incident on the lens, the area around the lens is entirely enclosed in a box with a shutter. The shutter is only opened when a measurement is being made. In addition, the lens is periodically cleaned using both a contact and a noncontact process.

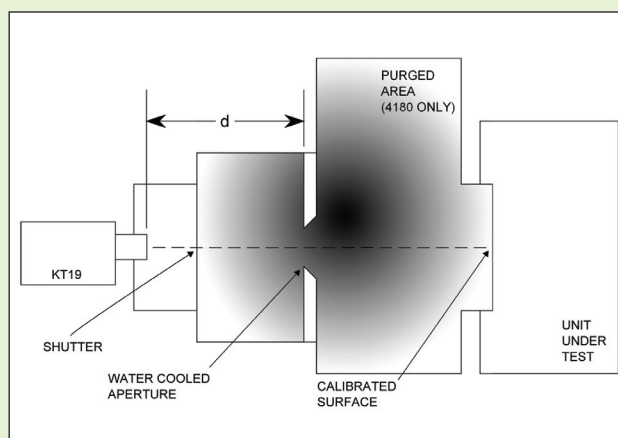

Figure 11. Flat plate calibration geometry.

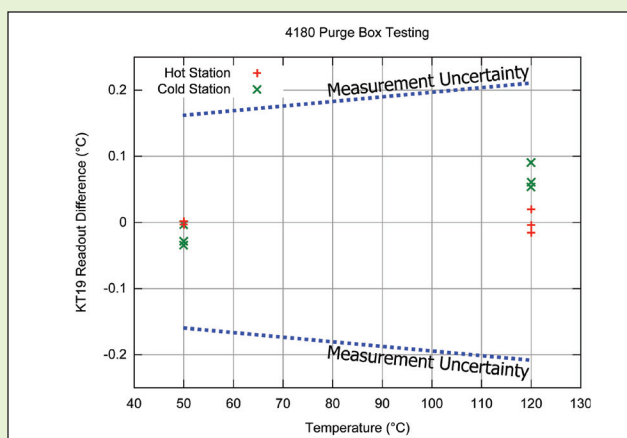

Figure 12. Radiometric measurements with and without purge chamber.

6. Conclusions

American Fork has established a quality radiation thermometry program by building and qualifying a series of blackbodies. The blackbodies have provided a radiation source for calibration of radiometric transfer standards. These transfer standards have been used to calibrate a series of flat-plate infrared sources intended for the calibration of handheld infrared thermometers. In addition to using a radiometric calibration for these sources, of other steps have been taken to ensure the quality of these calibrations.

7. Acknowledgements

The authors thank those who have helped develop the radiation thermometry capabilities at American Fork, especially Stephen King, formally of Raytek in Santa Cruz, California, who provided many ideas as this program developed. We also thank staff members of the Optical Technology Division of NIST who provided knowledge of great value, including Benjamin Tsai, Howard Yoon, Leonard Hanssen, Sergey Mekhontsev, and Charles Gibson. Finally we thank the management at American Fork for the opportunity to establish this program.

8. References

- [1] *Operational Instructions, Infrared Radiation Pyrometer KT 19 II*, Heitronics, Wiesbaden, Germany, 2005.
- [2] F. Liebmann, "Infrared Thermometer Calibrator Development at Fluke Corporation Hart Scientific Division," *P. Soc. Photo-opt. Ins.*, vol. 6939, no. 5, pp. 693906-1-693906-11, 2008.
- [3] A. V. Prokhorov and L. M. Hanssen, "Effective Emissivity of a Cylindrical Cavity with an Inclined Bottom," *Metrologia*, vol. 41, pp. 421-431, 2004.
- [4] V. I. Sapritsky and A.V. Prokhorov, "Spectral Effective Emissivities of Nonisothermal Cavities Calculated by the Monte Carlo Method," *Appl. Optics*, vol. 34, no. 25, pp. 5645-5652, 1995.
- [5] A.V. Prokhorov, "Monte Carlo Method in Optical Radiometry," *Metrologia*, vol. 35, pp. 465-471, 1998.
- [6] A. V. Prokhorov, S. N. Mekhontsev, L. M. Hanssen, "Radiative Properties of Blackbody Calibration Sources: Recent Advances in Computer Modeling," *Int. J. Thermophys.*, vol. 28, no. 6, pp. 2128-2144, 2007.
- [7] O. Struß, "Transfer Radiation Thermometer Covering the Temperature Range from -50 °C to 1000 °C," *AIP Conf. Proc.*, vol. 684, pp. 565-570, 2003.
- [8] C. E. Gibson, B. K. Tsai, A. C. Parr, "Radiance Temperature Calibrations," *NIST Special Publication 250-43*, pp. 9-36, 49-52, 1998.
- [9] F. E. Liebmann, T. Kolat, M. J. Coleman, and T. J. Wiandt, "Radiometric Comparison Between a National Laboratory and an Industrial Laboratory," *Int. J. Thermophys.*, vol. 32, no. 11, pp. 2533-2543, 2011.
- [10] J. Fischer, P. Saunders, M. Sadli, M. Battuello, C. W. Park, Y. Zundong, H. Yoon, W. Li, E. van der Ham, F. Sakuma, Y. Yamada, M. Ballico, G. Machin, N. Fox, J. Hollandt, M. Matveyev, P. Bloembergen and S. Ugur, "Uncertainty Budgets for Calibration of Radiation Thermometers below the Silver Point," *CCT-WG5 on Radiation Thermometry*, BIPM, Sèvres, 2008.
- [11] C. F. Dietrich, *Uncertainty, Calibration and Probability: The Statistics of Scientific and Industrial Measurement*, 2nd Ed., Adam Hilger, Philadelphia, pp. 282-283, 1991.
- [12] IEC, "Industrial process control devices - Radiation thermometers - Part 1: Technical data for radiation thermometers," *IEC 62492-1 T*, Geneva, p. 5, 2007.
- [13] ASTM, "Standard Test Methods for Radiation Thermometers (Single Waveband Type)," *Annual Book of ASTM Standards*, vol. 14.03, ASTM International, pp. 4-5, 2010.
- [14] M. Bart, E. W. M. van der Ham, P. Saunders, "A New Method to Determine the Size-of-Source Effect," *Int. J. Thermophys.*, vol. 28, no. 6, pp. 2111-2117, 2007.
- [15] C. D. Ehrlich, S. D. Rasberry, "Metrological Timelines in Traceability," *J. Res. Natl. Inst. Stan.*, vol. 103, no. 93, pp. 93-105, 1998.
- [16] M. G. Natrella, "Characterizing Linear Relationships between Two Variables," in *NBS Special Publication 300*, Vol. 1, edited by H. Ku, NBS, Washington, D. C., pp. 204-227, 1969.
- [17] J. V. Nicholas, D. R. White, *Traceable Temperatures*, Wiley, Chichester, UK, pp. 140-143, 2001.