

Y6270 Rack-Mount Kit

Instruction Sheet

Introduction

This sheet provides instructions to mount the 6270A Pressure Controller/Calibrator (the Product) in a standard 19.12 inch panel opening E.I.A. universal spacing equipment rack.

⚠ Warning

To prevent possible injury, do not restrict access to the Product power cord, which is the mains disconnecting device. If access to the mains power cord is inhibited by rack mounting, a properly-rated accessible proximate mains disconnecting switch must be provided as part of the installation.

Preparation

Before the rack-mount kit (the kit) is installed:

1. Remove the top and bottom screws from the sides of the front Product handles. Leave the center screws installed.
2. Remove the rear handles and slide out the center covers from the side extrusions.
3. Remove flat-head screws from side extrusion, 2 per side.
4. Use the screws removed from the rear handles (step 2) to install the handle caps.

Installation

Use this procedure to install the kit. For steps 1 through 3, see Figure 1. Figure 3 shows the fasteners and screws necessary.

1. Attach the rack ears to the Product using two M4 x 16 mm socket cap screws for each ear.

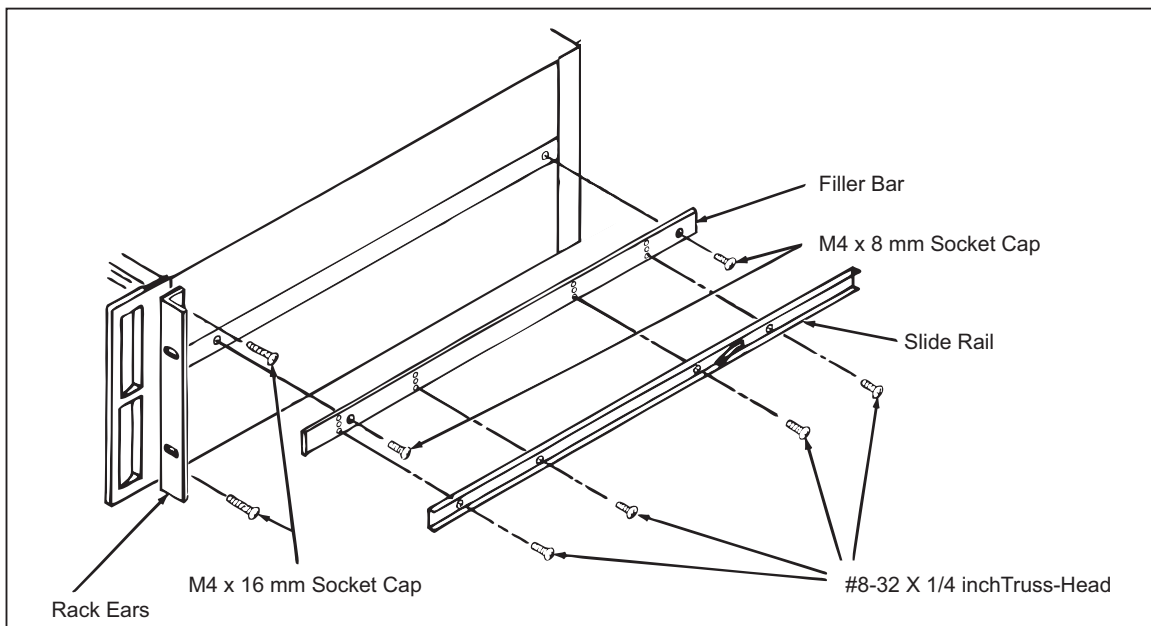

Figure 1. Attach the Hardware to the Product

hvi002.eps

2. Install the filler bars on the sides of the Product using two M4 x 8 mm socket cap screws for each bar. Make sure the first tapped hole closest to the end of the bar is toward the front of the instrument.
3. Remove inner section from slide rail assemblies, and attach to the filler bars using four #8-32 x 1/4 inch truss-head machine screws for each rail. Make sure the front edge of the slide is level with the front edge of the filler bar.
4. Install the front slide brackets (shorter pair) to the equipment rack mounting rails (Figure 2). (Refer to Figure 3 and 4 for typical mounting holes spacing.) If your rack has threaded mounting rails, use two #10-32 x 1/2 inch truss-head screws as shown in Figure 2, Detail A. If your rack has unthreaded mounting holes, use two #10-24 x 1/2 inch truss-head screws and two #10-24 U-nuts as shown in Figure 2, Detail B.
5. Install the rear slide bracket (longer pair) to the Product rack mounting brackets the same way as the front.
6. Attach the slides to the front brackets using two #8-32 x 1/2 inch pan-head screws, two #8 flat washers, two #8 lock washers, and two #8 hex nuts (see Figure 2). Align the slides to the rear brackets the same way as the front, except fully extend the slides to access the screw heads.
7. Put the Product into the slides, unlock the slides and push the Product into the rack.
8. Secure the Product to the rack by fastening the rack ears to the mounting rails with two #10-32 x 3/4 inch decorative-head screws for each ear. If your rack has unthreaded mounting rails, install two #10-32 U-nuts in appropriate places in the rail holes.

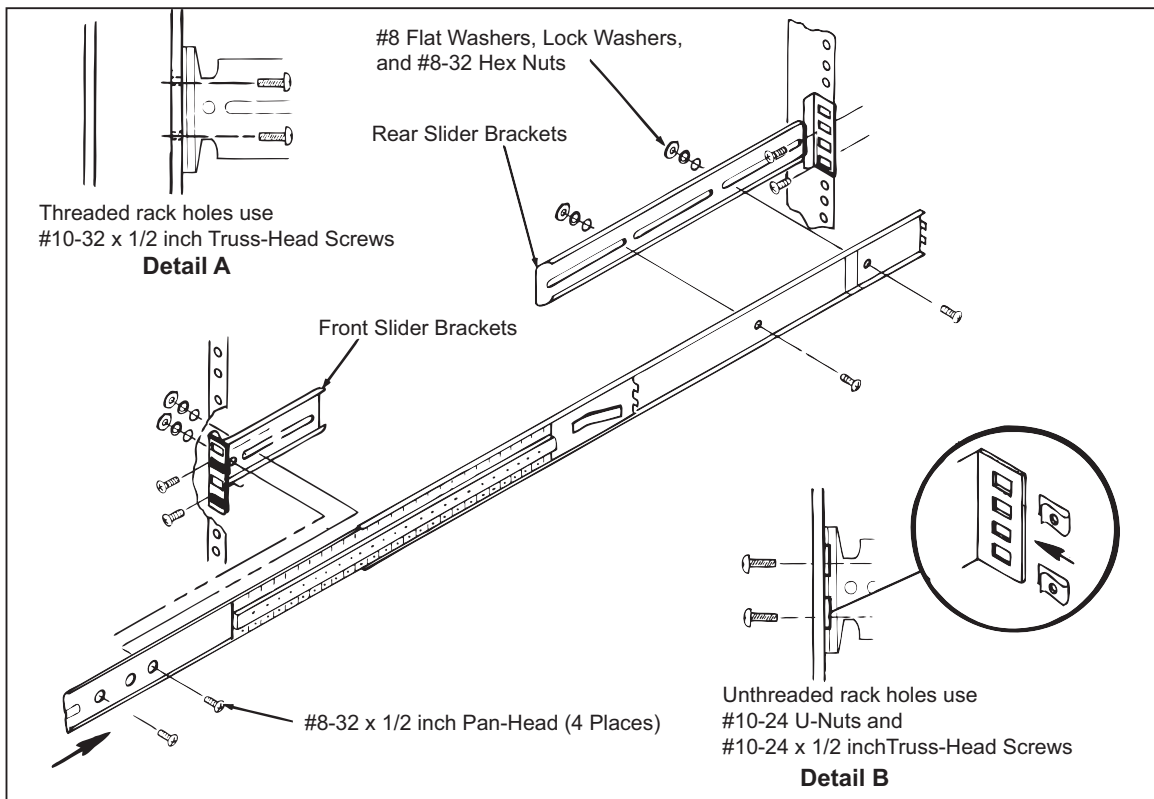

Figure 2. Install the Rack Slides

hvt003.eps

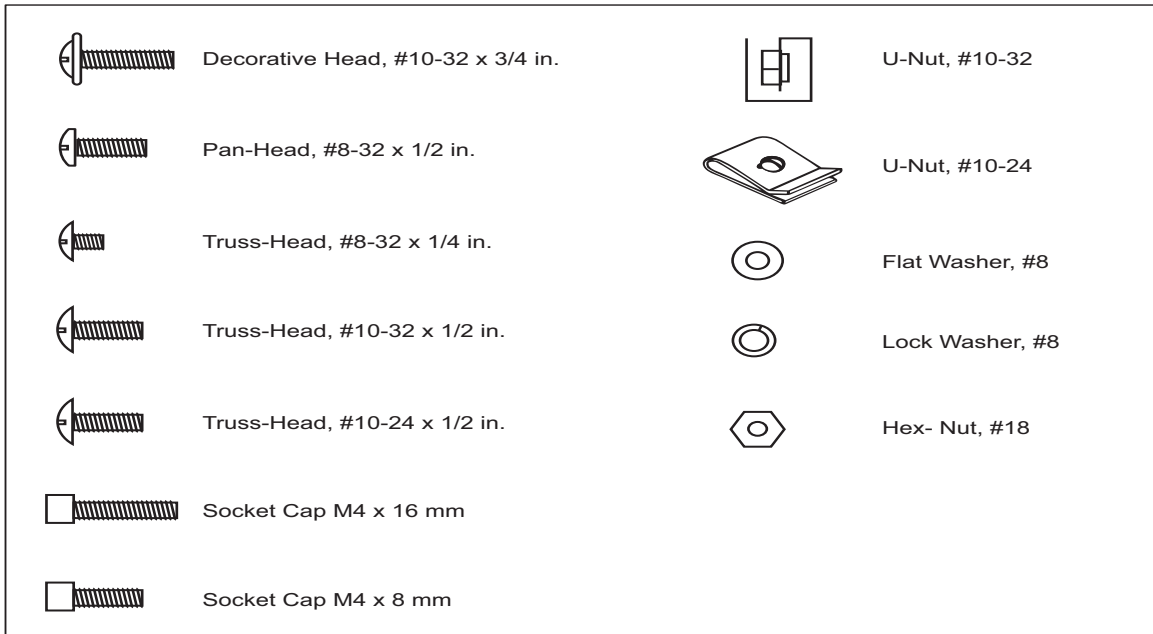

Figure 3. Screw Identification

hvi005.eps

Contact Fluke Calibration

To contact Fluke Calibration, call one of the following telephone numbers:

- Technical Support USA: 1-877-355-3225
- Calibration/Repair USA: 1-877-355-3225
- Canada: 1-800-36-FLUKE (1-800-363-5853)
- Europe: +31-40-2675-200
- Japan: +81-3-6714-3114
- Singapore: +65-6799-5566
- China: +86-400-810-3435
- Brazil: +55-11-3759-7600
- Anywhere in the world: +1-425-446-6110

To see product information and download the latest manual supplements, visit Fluke Calibration's website at www.flukecal.com.

To register your product, visit <http://flukecal.com/register-product>

