

# MNR 150

## HYDRAULIC COMPARISON TEST PUMP

- RUGGED AND SOLID DESIGN, STAINLESS STEEL
- EASY PRIMING AND PRESSURE GENERATION
- EASY TO OPERATE
- LARGE 26 CC VOLUME DISPLACEMENT

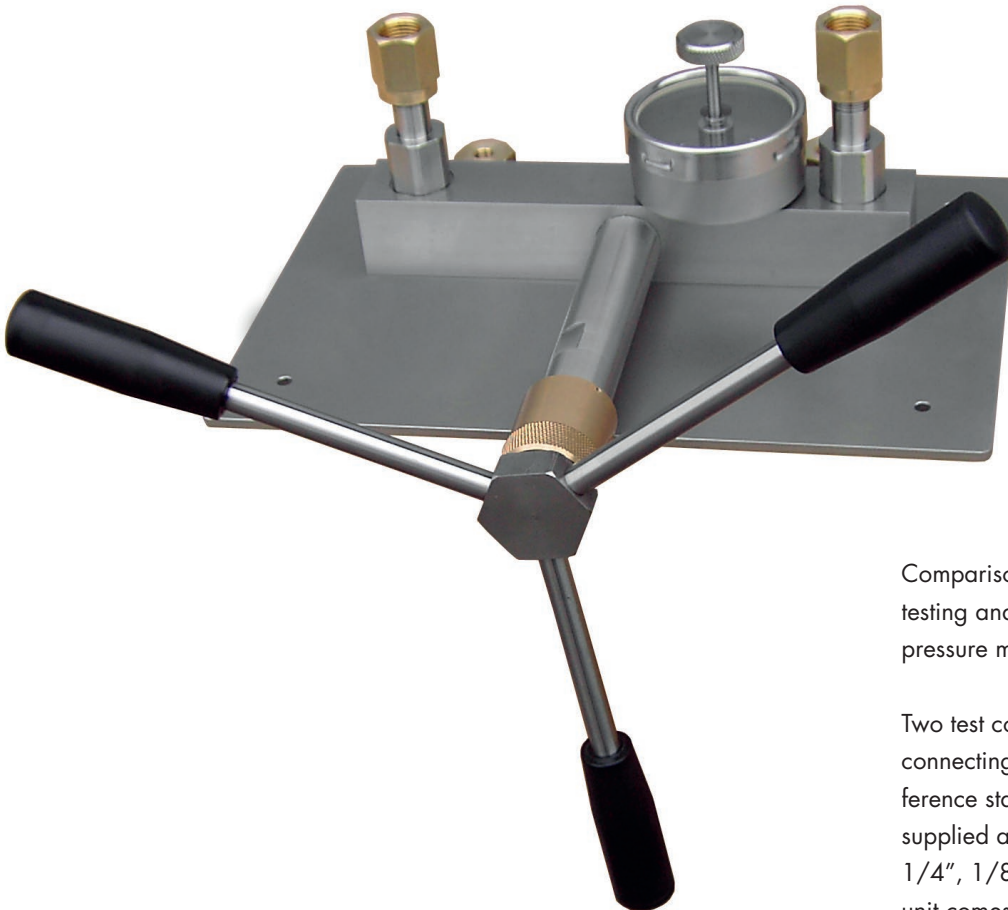

Comparison test pumps are used for testing and calibration for all kind of pressure measurements equipment.

Two test connections are available for connecting device under test and your reference standard. A full set of adapters is supplied as standard containing; 1/8", 1/4", 1/8", 2 x 1/2" BSP female. The unit comes with 1/2 liter Nuto H32- oil.

The pump is suitable for use with oil and also water in case the devices should not be contaminated with oil due to the application for which it is used.

## TECHNICAL SPECIFICATIONS

Models	MNR 150 - 700, 0 - 700 bar oil (70 MPa / 10.000 psi) MNR 150 - 1000, 0 - 1000 bar water (100 MPa / 15.000 psi) MNR 150 - 1400, 0 - 1400 bar oil (140 MPa / 20.000 psi)
Supply	Set of adapters; 1 x 1/8" BSP, 1 x 1/4" BSP, 1 x 3/8" BSP, 2 x 1/2" BSP and 1/2 liter Nuto H32-oil
Material:	
connections	2 x 3/8" BSP left male
bottom plate	Stainless steel with four mounting holes for stable setting
filling fluids	Suitable for oil and water (other fluids on request)
wetted parts	Pump stainless steel, nitril and viton seals and brass adapters

## RELATED PRODUCTS

- MNR 130 Dirt / moisture trap
- MNR 140 Oil-gas separator

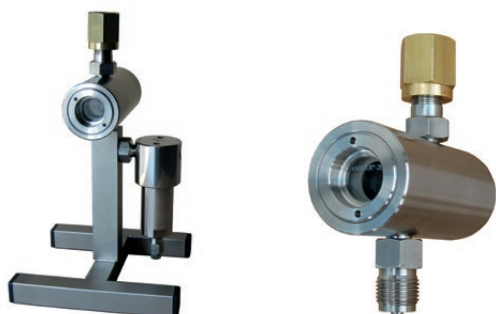

your distributor:



**Minerva** meettechniek B.V.  
 Chrysantstraat 1  
 3812 WX Amersfoort, the Netherlands  
 tel. +31 33 46 22 000  
 info@minervaipm.com